

HANS™ Premium Water Model 2 / Model 2R



Owner's Manual

8900-04



Model 2 is certified by IAPMO R&T to NSF/ANSI 61, CSA B483.1, LEC 2006 and ASSE 1087, and NSF/ANSI 244* for reduction/inactivation of pathogenic (disease-causing) bacteria, viruses and cysts. The Model 2 is certified by IAPMO R&T to NSF/ANSI 53 for VOC reduction when the system uses two 8331 filters.



Model 2 has been evaluated by ASSE International for Halal compliance.



Model 2 is certified by ASSE International to LEC 2006.



Model 2 is certified by Intertek to UL 979.

* NSF/ANSI 244 certification is valid when the systems use; 8017 RO Element.

Document Revision Table

Revision	Date	Section(s) Revised: Description
01	10.01.2020	N/A
02	11.02.2020	All: General and clerical updates
03	12.30.2020	General Information: Updated information for use with private wells. Terms & Definitions: Updated filter nomenclature. Water Source: New single screen with settings for any water source. Warnings & Alerts: Added alert for Stage 1&2 – Check Filters, added alerts for VOC filter life.
04	01.11.2021	General: Manual updated to include Model 2R Specifications: Added Model 2R specs. Updated inlet water specs. System Overview: Added Model 2R single RO cassette

Table of Contents

General Information

HANS Premium Water Appliance.....	5
Safety.....	5
California Proposition 65 Warning.....	9
Warranty/Terms of Use.....	9

Terms and Definitions.....	10
----------------------------	----

System Specifications.....	11
----------------------------	----

System Overview.....	13
----------------------	----

Installation & Start-Up.....	14
------------------------------	----

Display Navigation

Home Screen.....	15
Menu Screen.....	16
Sensors Screen.....	17
Controls Screen.....	18

Table of Contents (continued)

Display Navigation (continued)

Solenoids Screen.....	19
Service Screen.....	20
Filters Screen.....	21
Water Source Settings.....	22
TDS Settings.....	23
Basic System Settings.....	24
System Diagnostics.....	25
System Restart.....	26
Wi-Fi Set-up.....	27
Software Updates.....	30
Operational States.....	31
Warnings / Alerts.....	35
Troubleshooting.....	41

General Information

Please refer to the **HANS™ Premium Water** website for most current version of this manual as well as the Performance Data Sheets.

HANS™ Premium Water Appliance

The HANS™ Premium Water Appliance is a durable piece of equipment, which, with proper care, will last for many years. This Owner's Manual outlines operation and troubleshooting details vital to its sustained performance.

If the system is altered at the site of operation or if the inlet water conditions change, please contact your local dealer or distributor to determine proper recovery for your use.

Prior to operating or servicing the HANS™ Premium Water Appliance, this manual must be read and understood. Keep this and all associated documentation for future reference and for new operators or qualified personnel near the system.

Safety

The various safety headings used throughout this manual's text are defined below:



NOTE: Identifies statements that provide further information and clarification.



CAUTION: Identifies conditions or practices that could result in equipment or other property damage.



WARNING: Identifies conditions or practices that could result in injury or loss of life. Failure to follow warnings could result in serious injury or death.

DO NOT REMOVE UNDER ANY CIRCUMSTANCE, CAUTION, WARNING, OR OTHER DESCRIPTIVE LABELS FROM THE APPLIANCE.

General Information (continued)

Read this manual and the Installation Manual before installing and using the HANS™ Premium Water Appliance. Follow steps exactly to install the appliance correctly. Failure to do so could cause personal injury or property damage. Use this manual to help provide you with all the benefits of the HANS™ Premium Water Appliance.

As with any water system, it is highly recommended that a leak detection and water main shut-off valve be installed to prevent property damage due to a plumbing or system failure.

Do not use the HANS™ Premium Water Appliance to create safe, drinkable water that is from non-potable water sources. Do not use this appliance on microbiologically unsafe water or water of unknown quality without disinfecting.

For use with private wells:



WARNING: Do not use on private well water until the water has been tested by a certified drinking water laboratory to determine microbial safety in accordance with regulatory standards. Before using this device on a private well, it is the responsibility of the user to have the well tested by a certified drinking water laboratory. For continuous use of this device on a private well, it is the responsibility of the user to obtain frequent microbiological testing (recommended twice per year, minimum) of the well water entering the system by a certified drinking water laboratory to monitor continued compliance with the applicable regulatory standards. If the well source becomes microbiologically contaminated as indicated by testing, discontinue use of this device until sufficient well treatment and testing indicates that the water again meets the applicable regulatory standards. Following exposure of the device to microbiologically contaminated water and prior to its reuse, conduct the proper sanitization and servicing as directed in the owner's manual.



WARNING: This system may not perform as claimed unless all functional components are installed in their proper sequence in accordance with the installation and maintenance instructions.

This system has been tested according to NSF/ANSI 244 for reduction / inactivation of pathogenic (disease-causing) bacteria, viruses and cysts. The concentration of the indicated bacteria and virus surrogates in water entering the system was reduced to meet the reduction criteria, as specified in NSF/ANSI 244. The bacteria and virus surrogate reduction indicates verification of cyst reduction.

This system not intended to control all heterotrophic plate count (HPC) bacteria.

General Information (continued)



WARNING: This system is for use on water supplies that have been treated to public water system standards or otherwise are determined to be microbiologically safe as demonstrated by routine testing. This system has been tested to demonstrate protection against intermittent accidental microbiological contamination of otherwise safe drinking water.

Do not use with water that is microbiologically unsafe or of unknown quality. This system is not intended for use during a boil water advisory. Stop using this filter system when a boil water advisory is issued. After a boil water advisory has been discontinued and prior to reuse, sanitize and service the system as directed in the service & maintenance manual.



GROUNDING INSTRUCTIONS: This appliance must be grounded. In the event of a malfunction or breakdown, grounding will reduce the risk of electric shock by providing a path of least resistance for electric current. This appliance is equipped with a cord having an appliance-grounding conductor and a grounding plug. The plug must be plugged into an appropriate outlet that is installed and grounded in accordance with all local codes and ordinances.



WARNING: Improper connection of the appliance-grounding conductor can result in a risk of electric shock. Check with a qualified electrician or service representative if you are in doubt whether the appliance is properly grounded. Do not modify the plug provided with the appliance; if it will not fit the outlet, have a proper outlet installed by a qualified technician.



WARNING: It is the user's responsibility to heed all alerts and warnings from the system concerning calcite cartridge from the onboard display and the mobile app, as these replaceable treatment components are critical to proper system performance.

The manufacturer also recommends that the user periodically test the product water to verify the system is performing correctly.

General Information (continued)

Check with local public works department for plumbing and sanitation codes. Follow their guides as you install the HANS™ Premium Water Appliance. Follow local codes if they differ with guides in this manual.



In Massachusetts, plumbing code 248-CMR 3.00 and 10.00 shall be adhered. Consult with a licensed plumber.

Avoid installing this appliance in direct sunlight. Excessive heat may cause distortion or other damage to non-metallic parts.

If installing the HANS™ Premium Water Appliance outdoors, do not locate where it will be exposed to wet weather, direct sunlight, or extreme hot or cold temperatures. The system requires an ambient temperature range of 35 to 120 degrees Fahrenheit.

This HANS™ Premium Water Appliance has a non-metallic valve system. Installing it on metal plumbing will break electrical continuity, which may interrupt grounding for your home. You must restore electrical continuity in your metal plumbing system. Please refer to the Installation Manual for further information.



WARNING: Air gap appliance should be plumbed to state and regional codes and used to connect the reject water outlet to a drain connection.

While this Reverse Osmosis system contains replaceable treatment components to raise pH, RO water can lower pH. As this can be corrosive to some plumbing materials, care should be taken to properly maintain your system.

General Information (continued)

California Proposition 65 Warning



WARNING: This product contains chemicals known to the State of California to cause cancer and birth defects or other reproductive harm. For more information and questions, please refer to The Office of Environmental Health Hazard Assessment for California at: oehha.ca.gov/proposition-65/about-proposition-65.

Warranty/Terms of Use

Please refer to the **HANS™ Premium Water** website for Terms of Sale and Warranty Information. This information can be found at:

www.HansPremiumWater.com



Terms & Definitions

TERMS	DEFINITIONS
Ambient temp	Air Temperature of the immediate area around the system
Chlorine	Water additive in inlet water; may be used as a disinfectant
Inlet Water	Unfiltered water from municipal or well that is plumbed into the system
Filtered Water	Clean water output from the system
gpg	Grains per gallon, a unit of measure of calcium carbonate
Hardness	Scale in grains per gallon rating amount of water impurities
Element	Reverse Osmosis "filter"
ppm	Parts per million , unit of measure for small concentrations of substances in water
pH	Scale of acidity from 0-14, with 7 being neutral
Surge tank	Internal storage tank used to store water and buffer outlet pressure
Stage 1 Filter	Standard – 10-micron sediment filter used as the 1 st filter of inlet water to remove debris (P/N 8233) Chloramine – Catalytic carbon (P/N 8331)
Stage 2 Filter	Standard – Catalytic carbon (P/N 8331) Chloramine – Catalytic carbon (P/N 8331)
Stage 3 Element	Reverse osmosis Elements used as final stage to clean inlet water (P/N 8017)
Stage 4 Filter	Standard & Chloramine – Calcite. Raises pH and re-mineralizes filtered water (P/N 8329)
Recovery rate	Amount of filtered water recovered compared to waste water in %
TDS	Unit of measure for total dissolved solids in water in ppm
Waste Water	Water carrying away contaminants from the Elements to the drain

Specifications

Inlet Water Source



The HANS™ Premium Water Appliance is designed to operate with a wide range of inlet water; however, refer to the **Max Inlet Water Levels document (P/N 5313)** for inlet water combination requirements.

If the inlet water parameters are outside the ranges indicated Max Inlet Water Levels document, a pre-treatment system will be required for the inlet water to the Model 2 system.

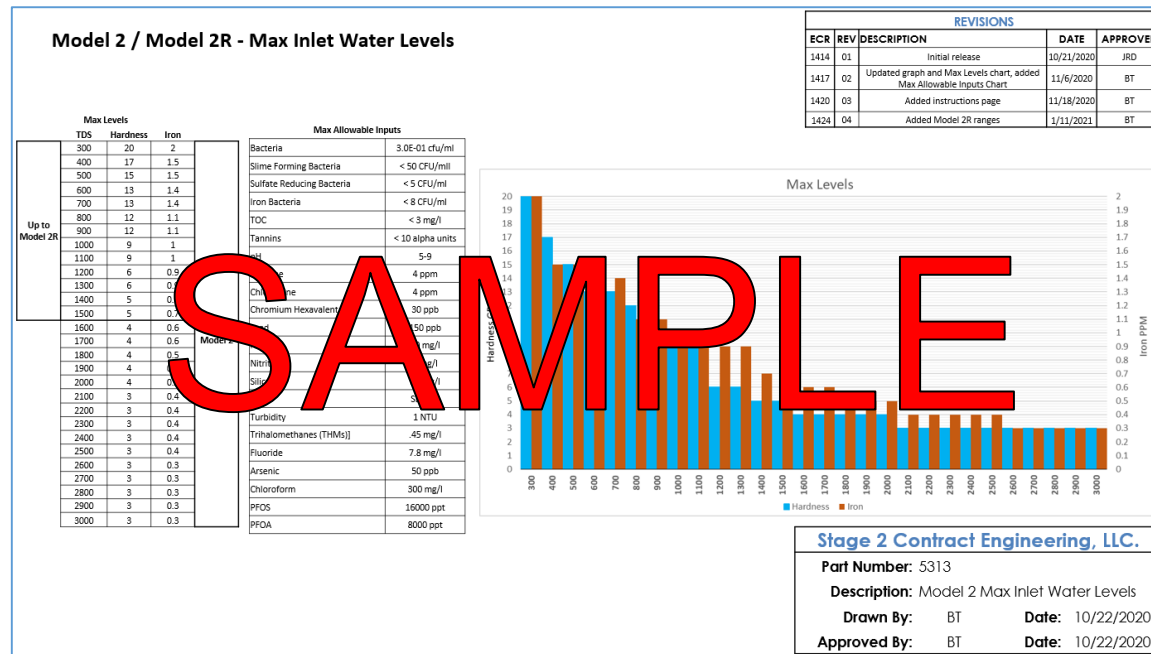

Sample illustration is for demonstration only. Refer to the Max Inlet Water Level document directly.

Higher inlet TDS and/or lower temperatures will reduce the system's water production output (efficiency).

For optimal performance if your system is on a well, use a 40/60 well switch with the minimum bound set to 45 psi. For inlet pressure that exceeds 60 psi, a pressure reducing valve (PRV) must be installed.

Specifications (continued)

Failure to meet minimum water requirements may cause the Elements to foul and void the manufacturer's warranty.

Combinations of TDS, Iron, Arsenic, hardness and other contaminants will change maximum specifications.

See Performance Data Sheet (<https://hanspremiumwater.com/faqs/>) for further information.

This Reverse Osmosis system contains replaceable treatment components critical for effective performance. It is the user's responsibility to heed all alerts and warning from the system concerning filter, calcite cartridge and element replacement from the on-board display and the mobile app. The manufacturer also recommends that the user periodically test the product water to verify the system is performing correctly.

Use only HANS™ Premium Water Replacement treatment components: Sediment Filter (P/N 8233), Catalytic Carbon Filter (P/N 8331), RO Element (P/N 8017), and Calcite Filter (P/N 8329). The use of any products other than HPW replacement filters, cartridges, elements, and/or parts will void warranty and invalidate all claims for health and performance.

System Overview

Exploded view of the overall system and identification of the various sub-assemblies.

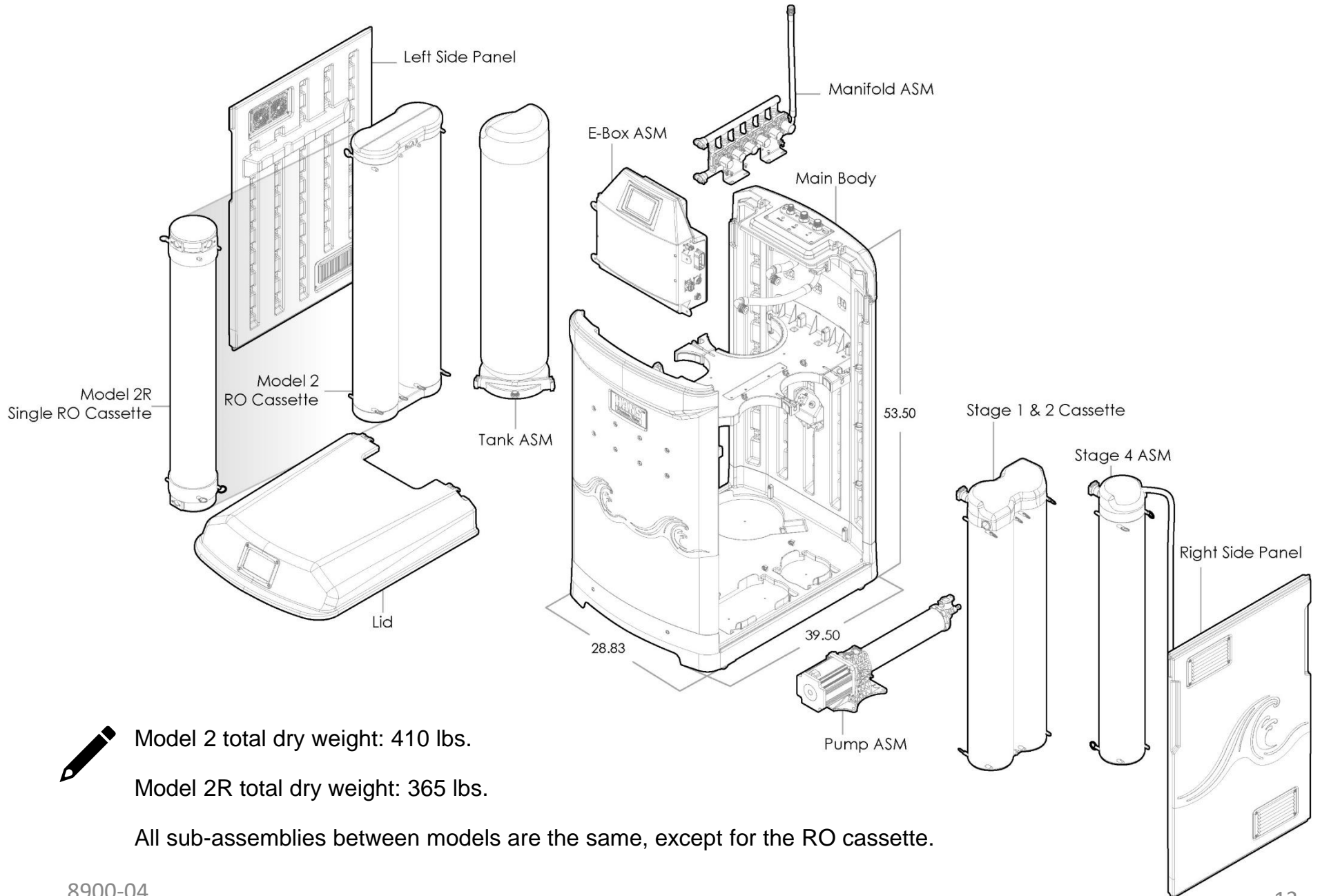

Model 2 total dry weight: 410 lbs.

Model 2R total dry weight: 365 lbs.

All sub-assemblies between models are the same, except for the RO cassette.

Installation & Start-Up

Installation should be performed by a qualified technician.



Refer to the HANS Premium Water Model 2 Installation Manual. Available for download at <https://hanspremiumwater.com/support>



HANS™ Premium Water Model 2 / Model 2R

Installation Manual

8900-04



Model 2 is certified by IAPMO R&T to NSF/ANSI 61, CSA B483.1, LEC 2006 and ASSE 1087, and NSF/ANSI 244* for reduction/inactivation of pathogenic (disease-causing) bacteria, viruses and cysts. The Model 2 is certified by IAPMO R&T to NSF/ANSI 53 for VOC reduction when the system uses two 8331 filters.



Model 2 has been evaluated by ASSE International for Halal compliance.



Model 2 is certified by ASSE International to LEC 2006.



Model 2 is certified by Intertek to UL 979.

* NSF/ANSI 244 certification is valid when the systems use; 8017 RO Element.

Display Navigation – Home Screen

The home screen displays all the pertinent operational parameters as well as filter life and total output (clean water).



From any screen, select the home button.

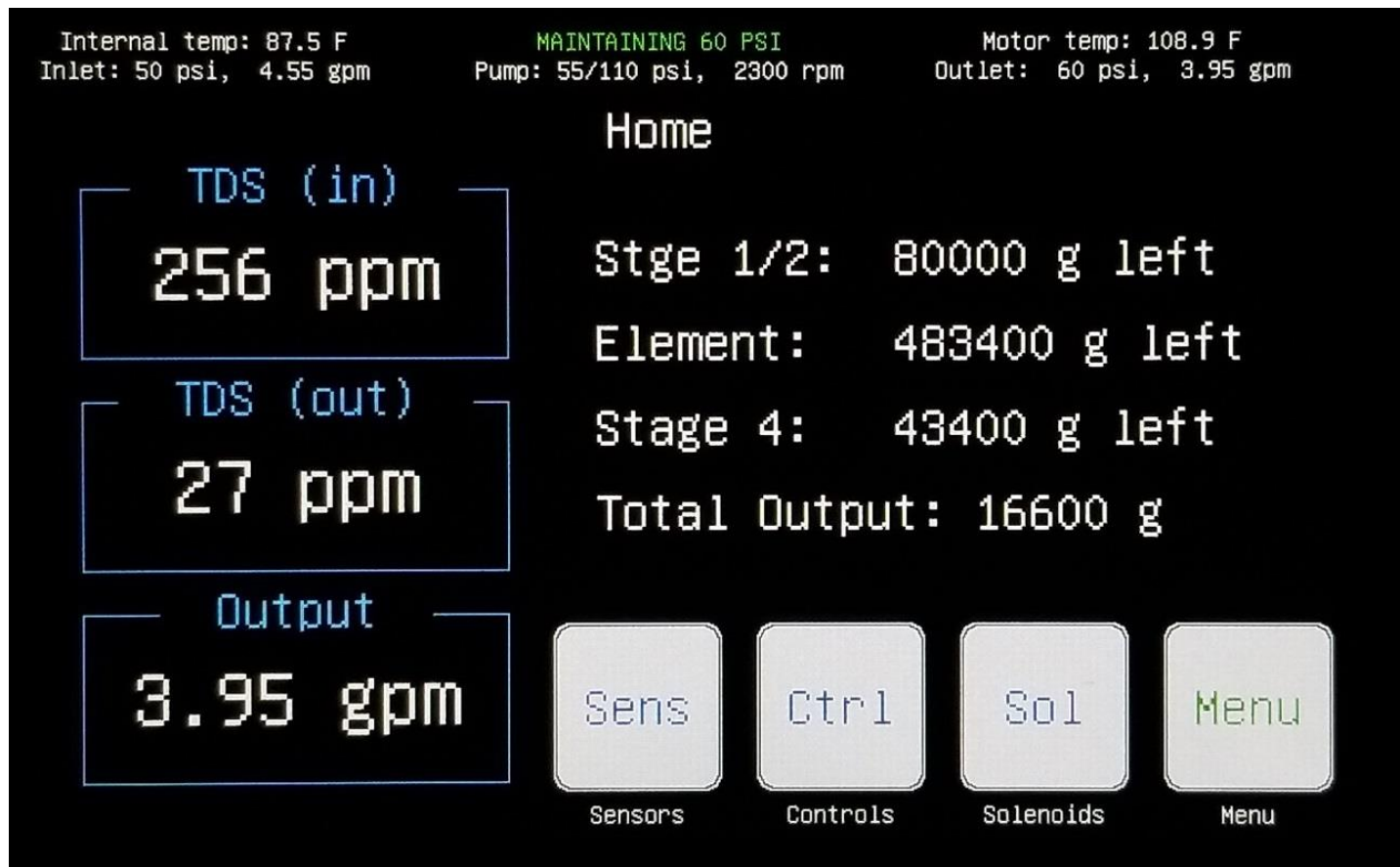

The top banner is universal across all screens and shows detailed operating data for the system.

Menu Screen

The menu screen is navigation hub which provides access to all sub-screens.



From the home screen, select menu.

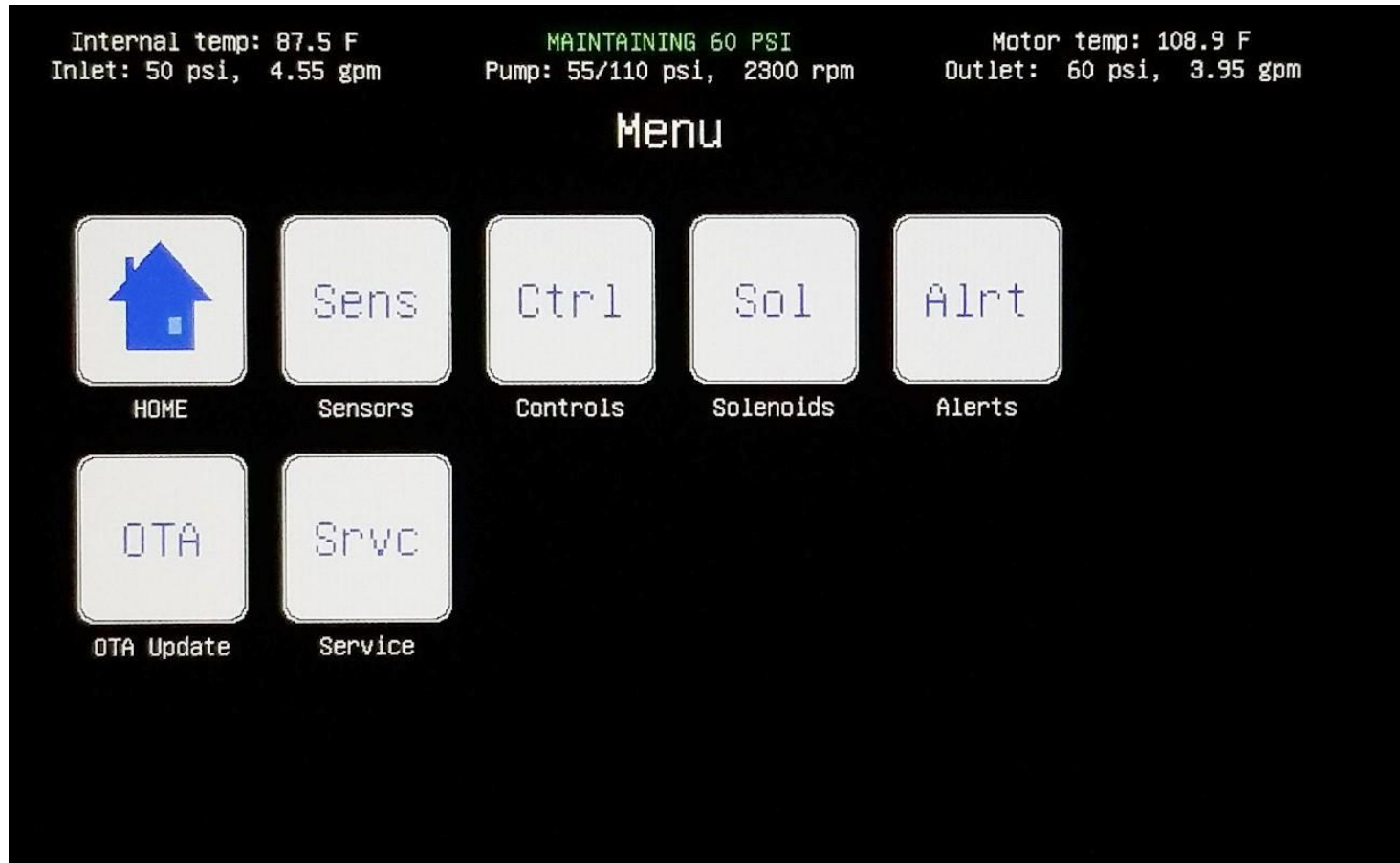

The sensors, controls, and solenoids screens primarily used during maintenance & service.

Sensors Screen

The sensors screen provides detailed operational data for all the system sensors.



From the home screen, select sensors.

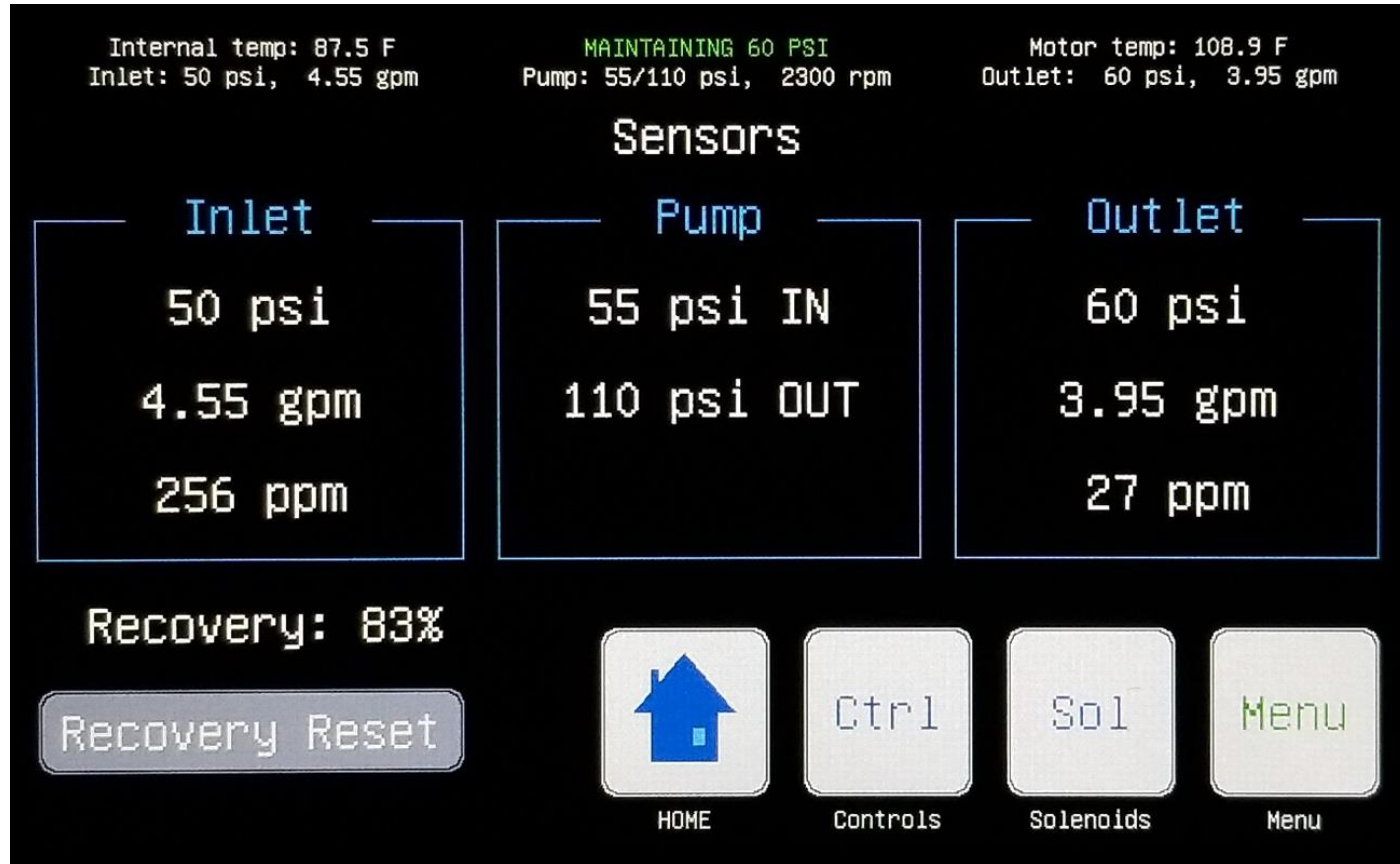

Recovery rate is a cumulative average since the last recovery reset. TDS readings are set to a default value of 100 after a reboot (power cycle) or software upgrade. TDS sensors require 1-minute of continuous operation before providing a dynamic reading.

Controls Screen

The controls screen provides manual/automatic pump control and allows the user to perform a drain cycle, sanitization (sani) cycle, forced (idle) flush, fan test, or start-up cycle.



From the home screen, select controls.



Only a qualified technician should operate the pump in manual mode.

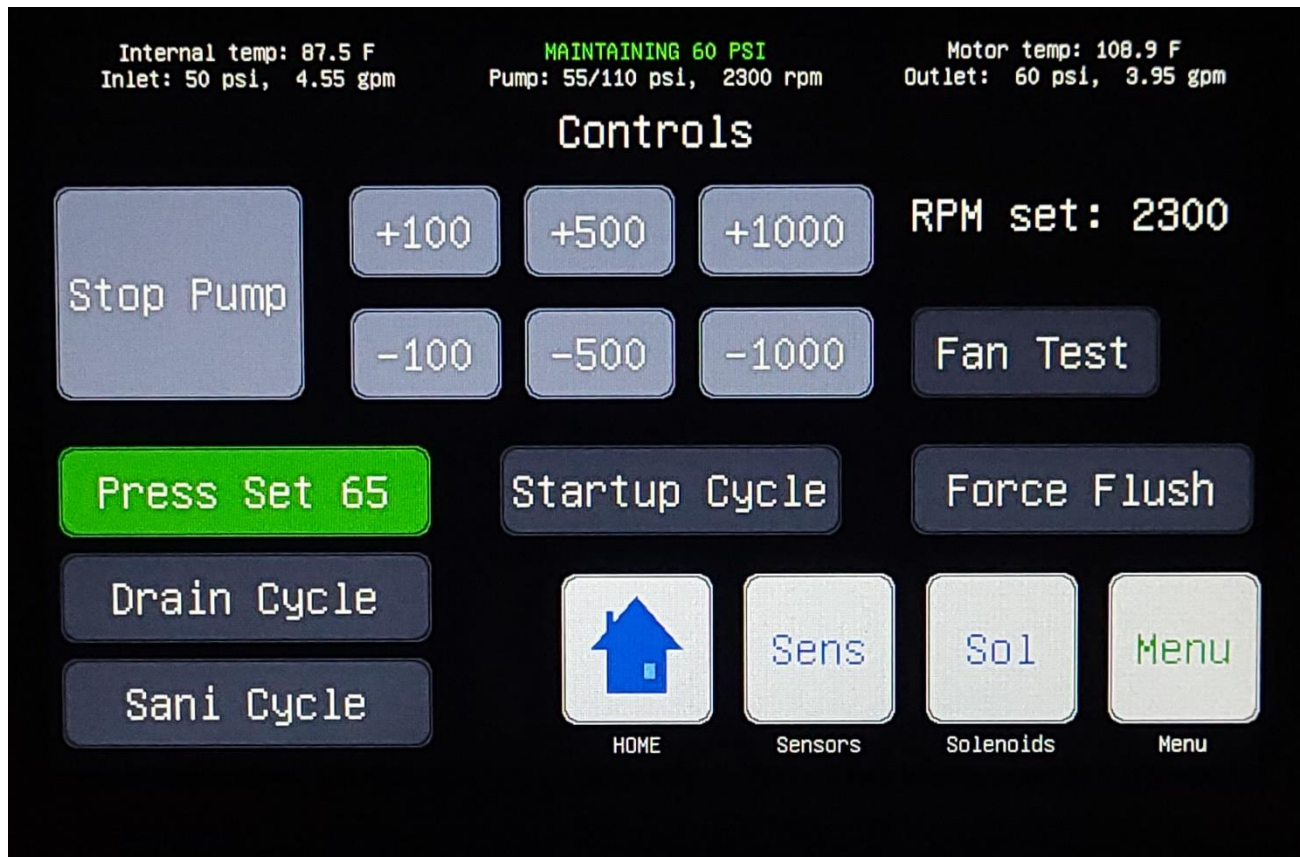

There is a 30 second delay to pump start-up after a system reset. During that delay, the controls screen offers the user the option to cancel automatic mode which will prevent the pump from starting.

Solenoids Screen

The solenoids screen provides a visual indication of which valves are open/closed during automatic operation while also providing the user with manual control of each solenoid when the system is in manual mode.



From the home screen, select solenoids.

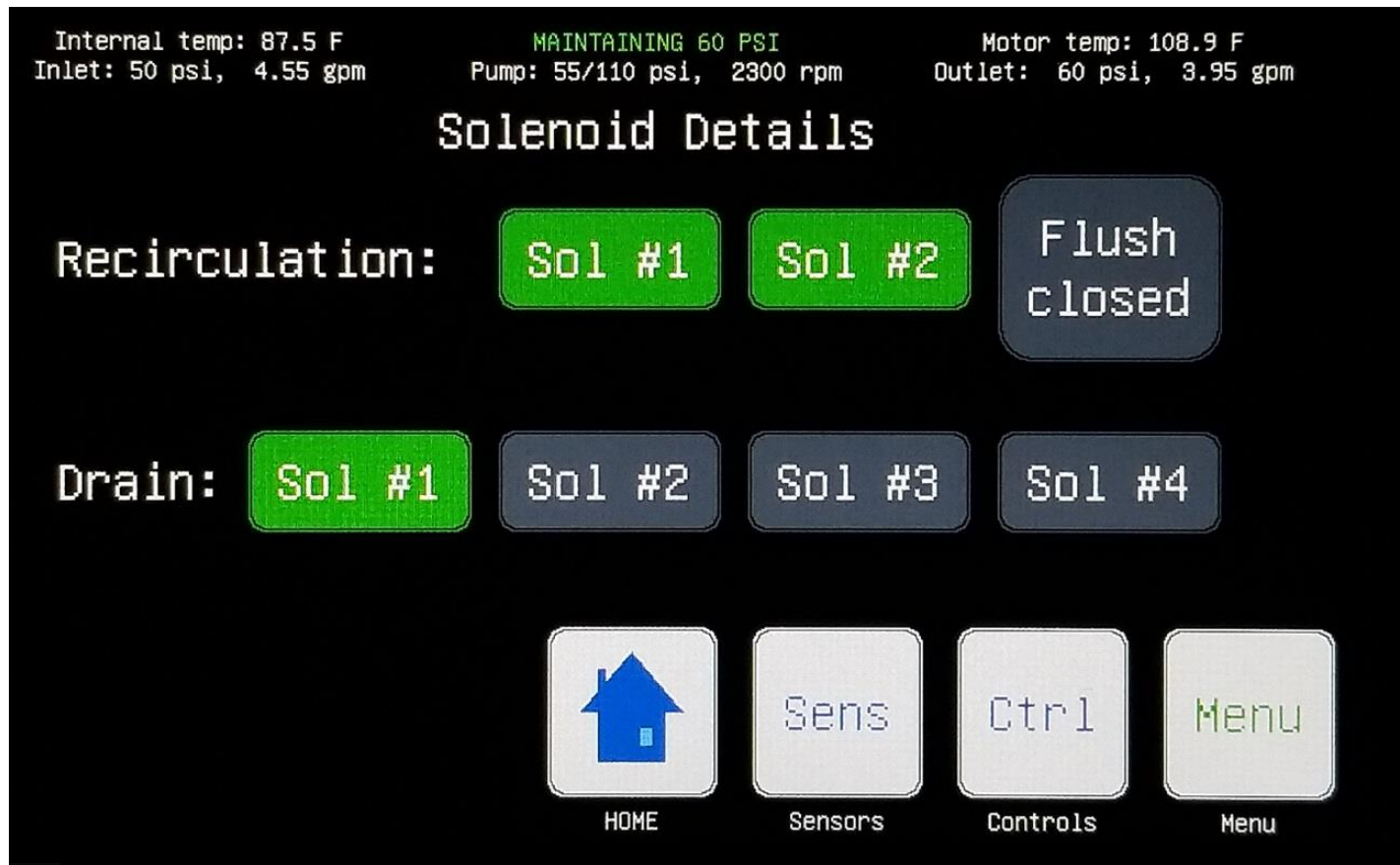

The system can only be placed into manual mode from the controls screen. A button highlighted in green indicates the valve is open.

Service Screen

The screen provides access to advanced system settings.



From the home screen, select menu, then service.

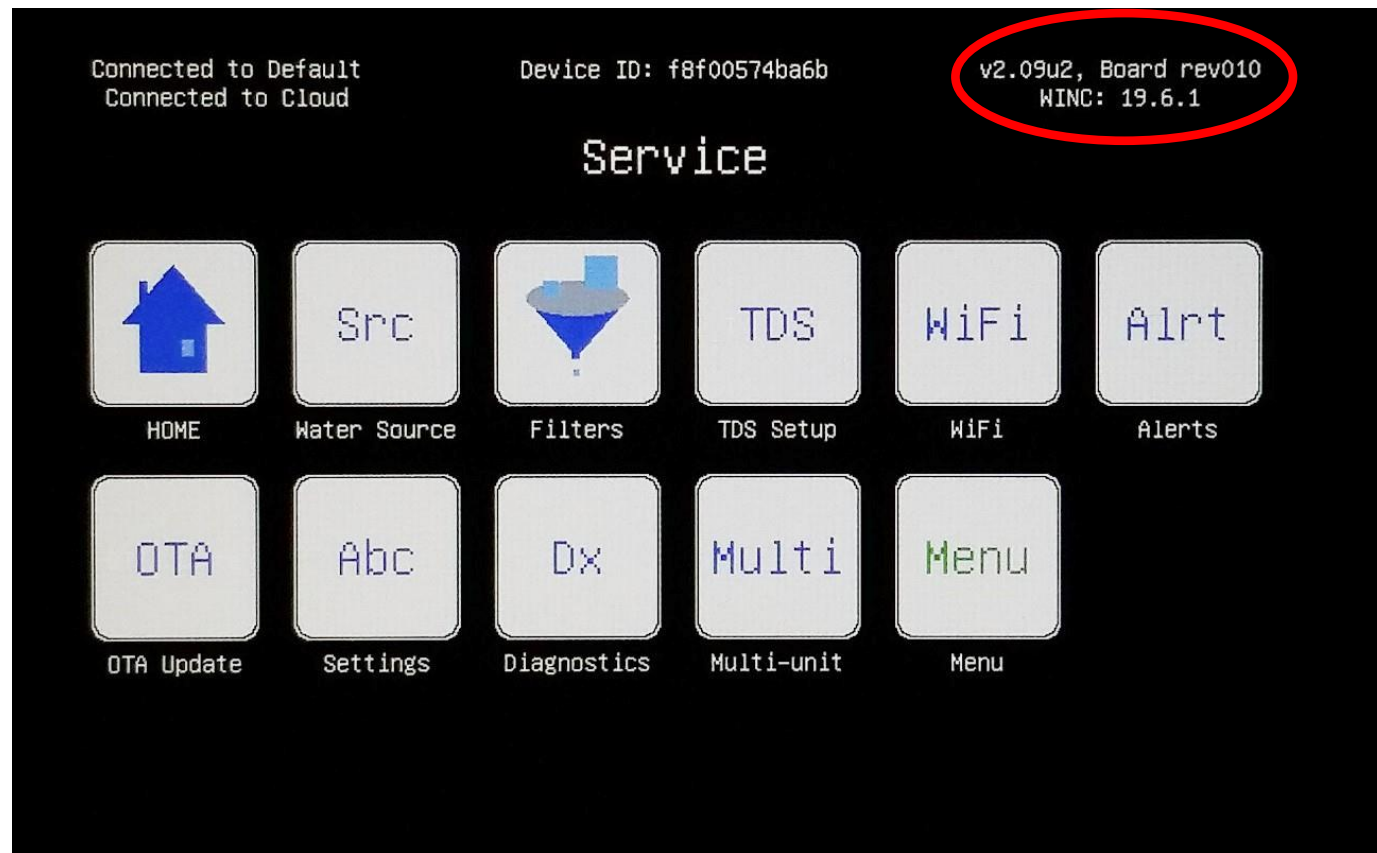

The service screen is typically only used during installation and/or service & maintenance. The current software and control board versions are listed in the upper right corner.

Filters Screen

The filter and element capacities are automatically calculated based on the characteristics of the inlet water. The filters screen displays: the maximum capacity (in gallons) for each filter, the current total usage (in gallons), and the estimated days remaining for each filter based on recent usage.



From the home screen, select menu, then service, then filters.

The screenshot shows the 'Filters' screen with the following data:

	Stg 1/2	Element	Stage 4
Max gals:	100000	500000	60000
Total use:	20000	16600	16600
Days left:	171	1209	109

System status at the top: Internal temp: 87.5 F, Inlet: 50 psi, 4.55 gpm; MAINTAINING 60 PSI, Pump: 55/110 psi, 2300 rpm; Motor temp: 108.9 F, Outlet: 60 psi, 3.95 gpm.

Navigation buttons at the bottom: HOME (house icon), Sens, Ctrl, Spvc. Three 'RESET' buttons are positioned below the filter data columns.



Filter capacity can be reset upon filter replacement by selecting the appropriate reset button for each stage.

Water Source Settings

Select the appropriate water source characteristics based on the pre-installation water testing. Filter capacities for the unit will be automatically calculated based on these user inputs.



From the home screen, select menu, then service, then water source.

Internal temp: 87.5 F
Inlet: 50 psi, 4.55 gpm

MAINTAINING 60 PSI
Pump: 55/110 psi, 2300 rpm

Motor temp: 108.9 F
Outlet: 60 psi, 3.95 gpm

Water Source

pH: 5.0-6.0 6.0-6.8 6.8 +

Hardness: 0 - 15 15+

Chlorine: Chlorine Chloramine

Chl Conc: 0-2 ppm 2-4 ppm

Iron: 0-1 1+ VOC ON

Srvc
Service



User has the option to enable filter capacity alerts for Volatile Organic Compounds (VOCs).

TDS Settings

Set the TDS range based on the results of the pre-installation water testing.



From the home screen, select menu, then service, then TDS settings.

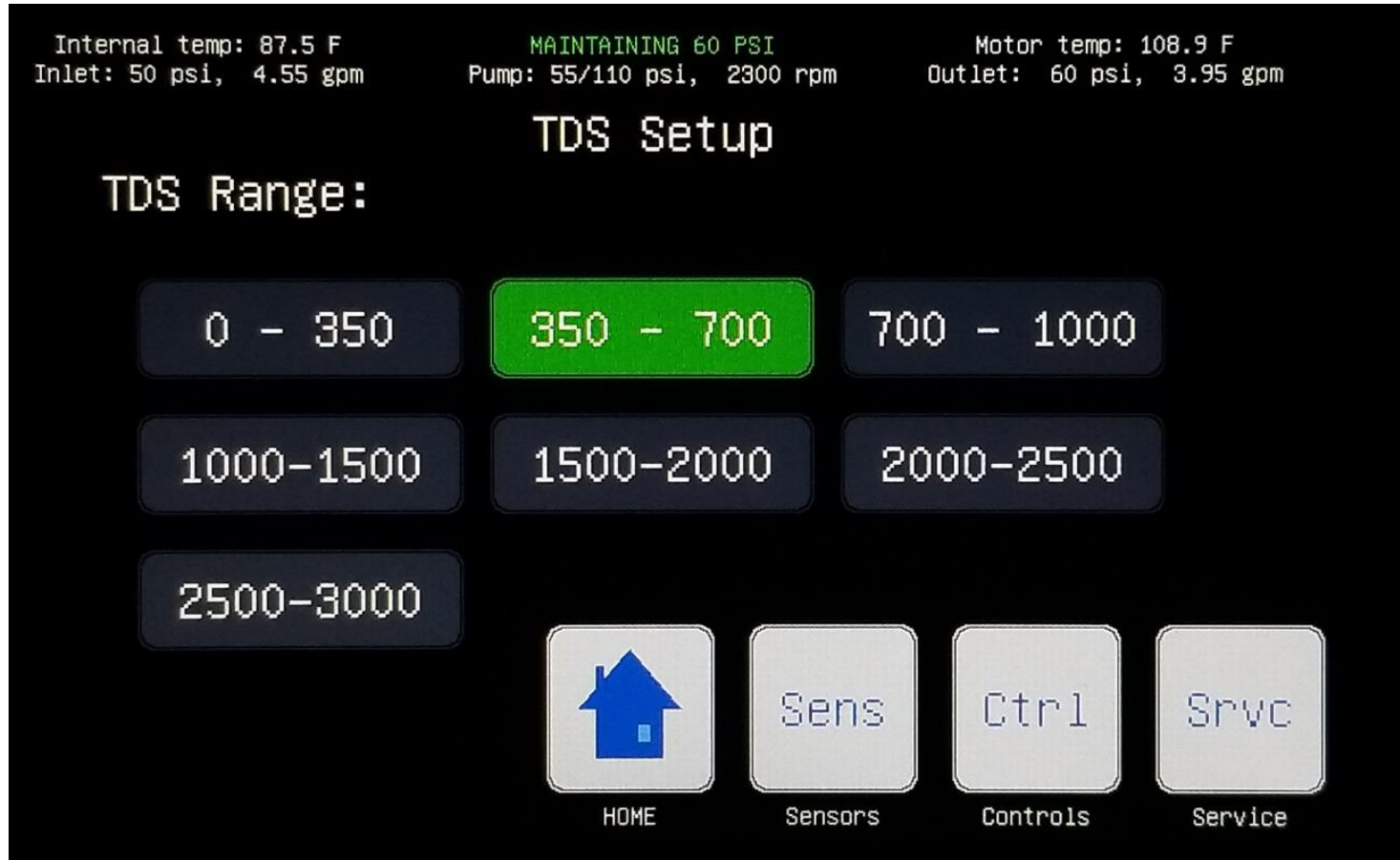

Once the TDS range is set, the inlet TDS value will not go below the indicated minimum value of the range.

Basic System Settings

The system has various settings which are based on the individual application, customer preferences, and the relevant market.



From the home screen, select menu, then service, then settings.

Operating Amps

- Maximum current load (draw) for the system, based on the electrical supply circuit.

Recovery Mode

- High – increased recovery rate during operation.
- Standard – standard recovery rate during operation.

Display Units

- Imperial or metric depending on market.

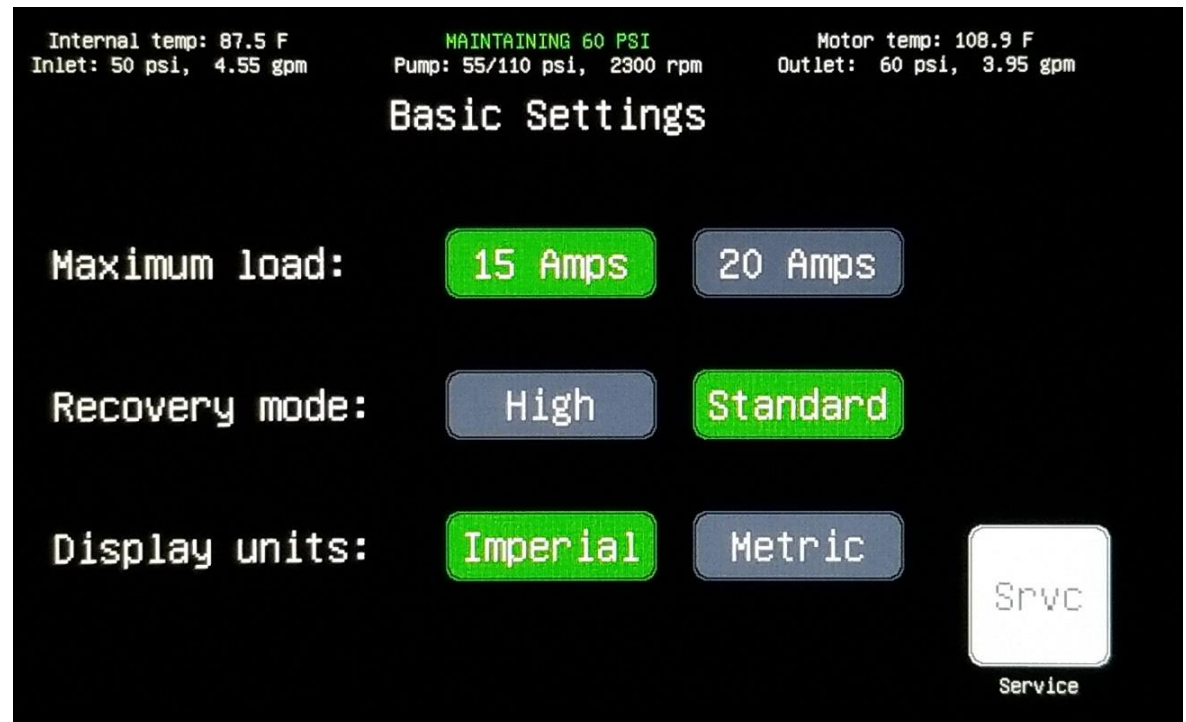

High Recovery may not be available for some inlet waters.

System Diagnostics

The diagnostics screen displays cumulative counts of any faults related to the various line items. This screen is typically used for service and/or troubleshooting. The total fault counts can be reset by pressing the 'reset counts' button.



From the home screen, select menu, then service, then diagnostics.

The screenshot shows the 'Diagnostics' screen with the following information:

- Internal temp: 87.5 F
- Inlet: 50 psi, 4.55 gpm
- Pump: 55/110 psi, 2900 rpm
- Motor temp: 108.9 F
- Outlet: 60 psi, 3.95 gpm

MAINTAINING 60 PSI

Diagnostics

Pump Faults:	0	Check TDS Sensor:	0
Solenoid Faults:	0	High Pump Press:	0
Low Inlet Press:	0	Low Outlet Press:	0
High Inlet Press:	0	High Outlet Press:	0
High Inlet TDS:	0		
High Outlet TDS:	0		
Resets:	34		

Buttons: Restart System, Reset Counts, HOME, Menu, Service

System Restart

If required, the system can be restarted manually.



From the home screen, select menu, then service, then diagnostics.

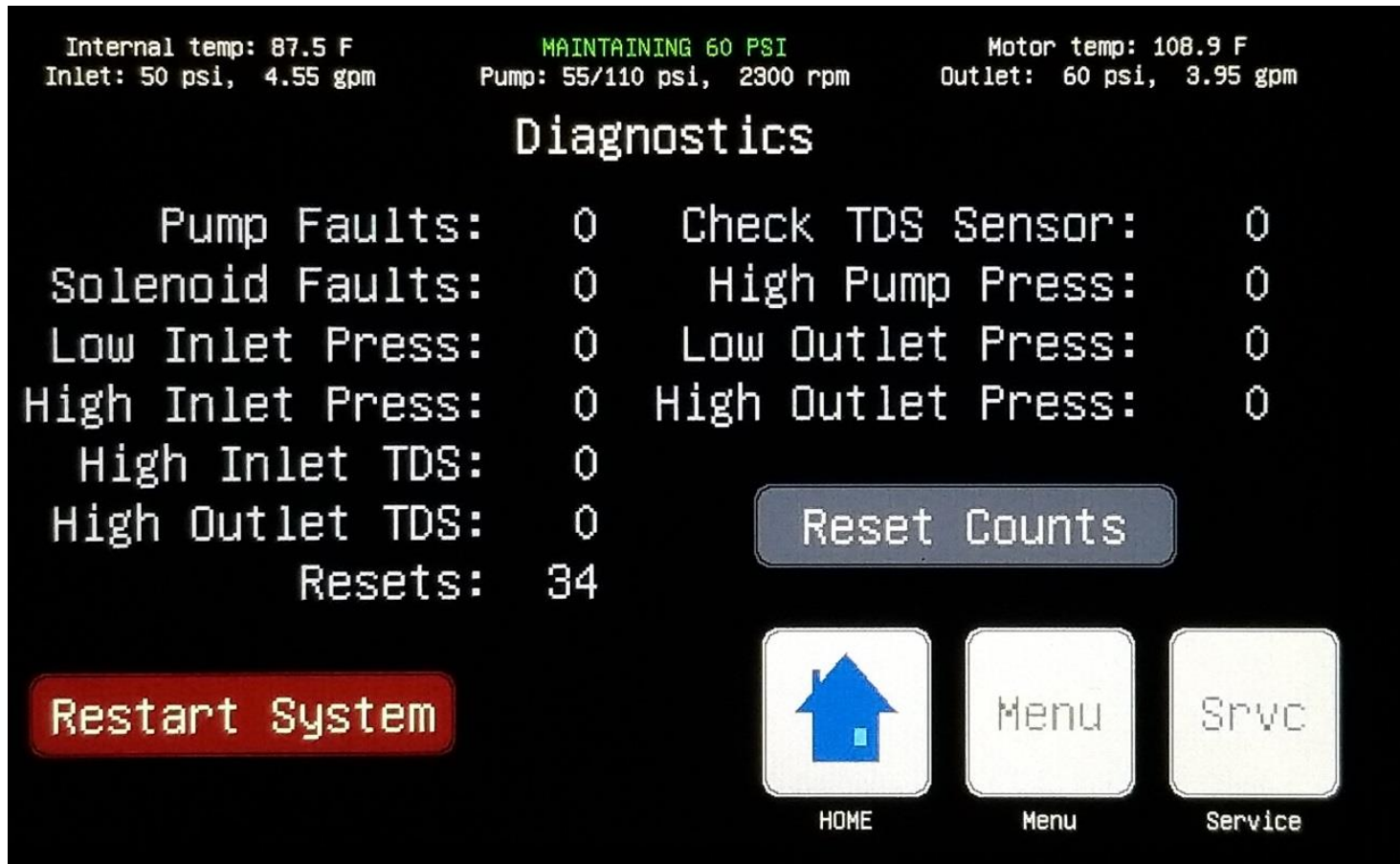

Pressing the 'restart system' button will produce a secondary confirmation window. The user may then select 'cancel' or 'restart'.

Wi-Fi Set-up

Configure the on-board Wi-Fi capability using the smart phone application.



Download the HANS Premium Water Application for your iOS or Android device.



1. If you're a first-time user, create an account.
2. Once logged-in, select 'Set Up New HANS Device'.
3. The app will direct the user to initialize Wi-Fi set-up on the HANS unit.

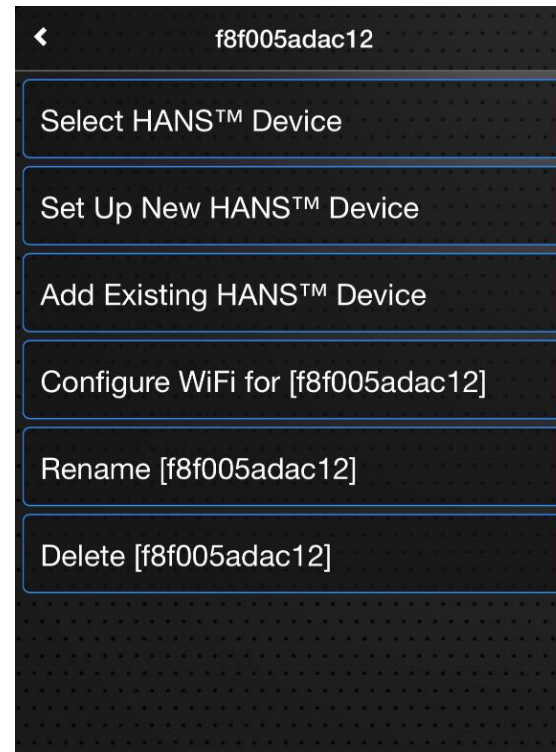
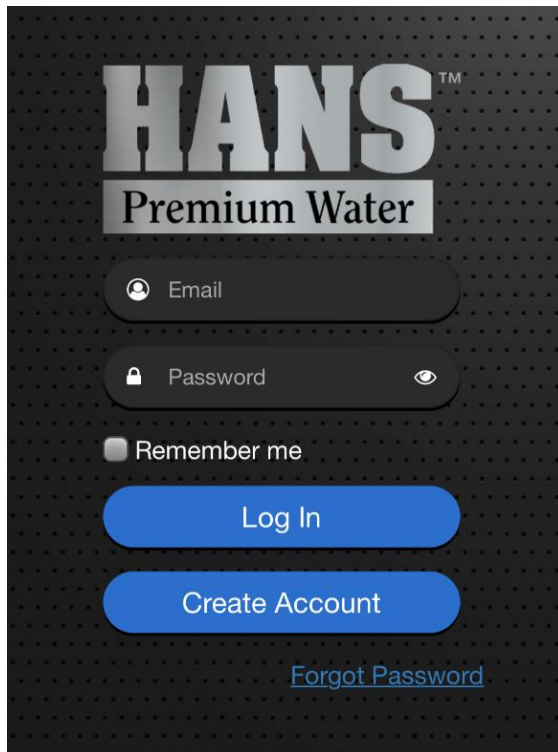

Wi-Fi Set-up (continued)



4. From the home screen of the HANS unit, select menu, then service, then 'Press to setup Wi-Fi'.
5. With the Wi-Fi Set-up initialized, the upper left corner of the screen will show 'Listening as HANS'



If properly connected to the router and cloud, it will be indicated in the upper left corner of the screen.

Wi-Fi Set-up (continued)

6. Join the 'HANS' Wi-Fi Network
7. Enter the Wi-Fi router name and password.
8. Verify connection to router and to cloud (see previous page).

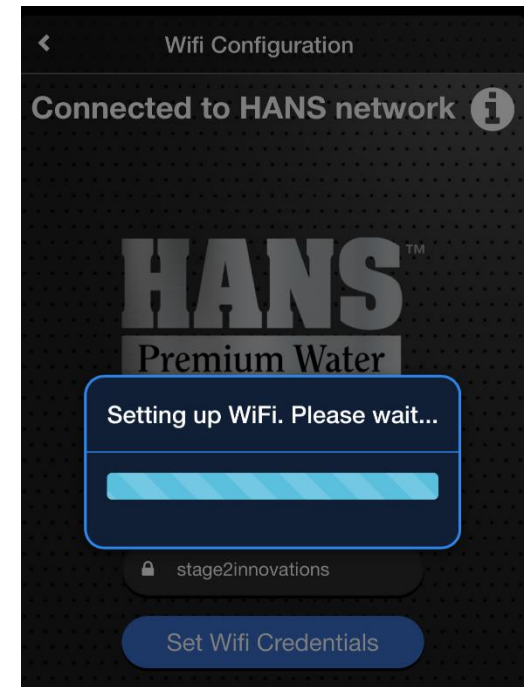
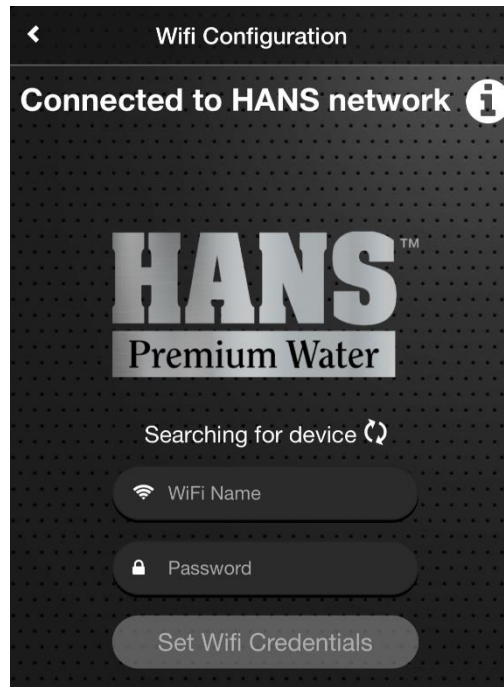
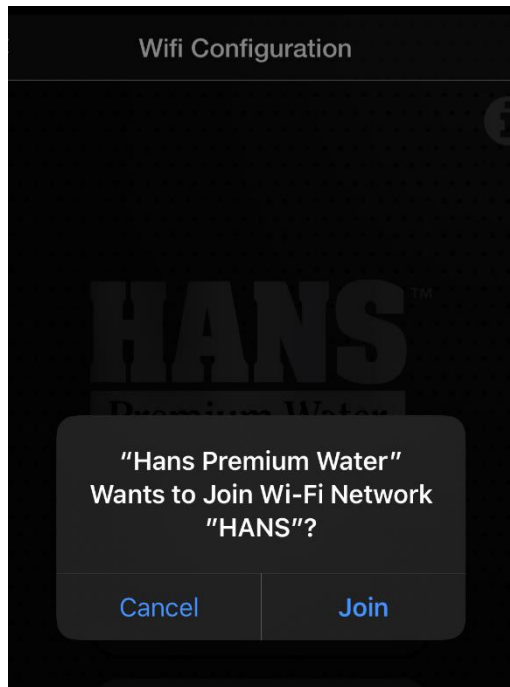

Software Updates

When connected to Wi-Fi and the cloud, the system can automatically download and install software updates with the push of a button.



From the home screen, select menu, then OTA Update.

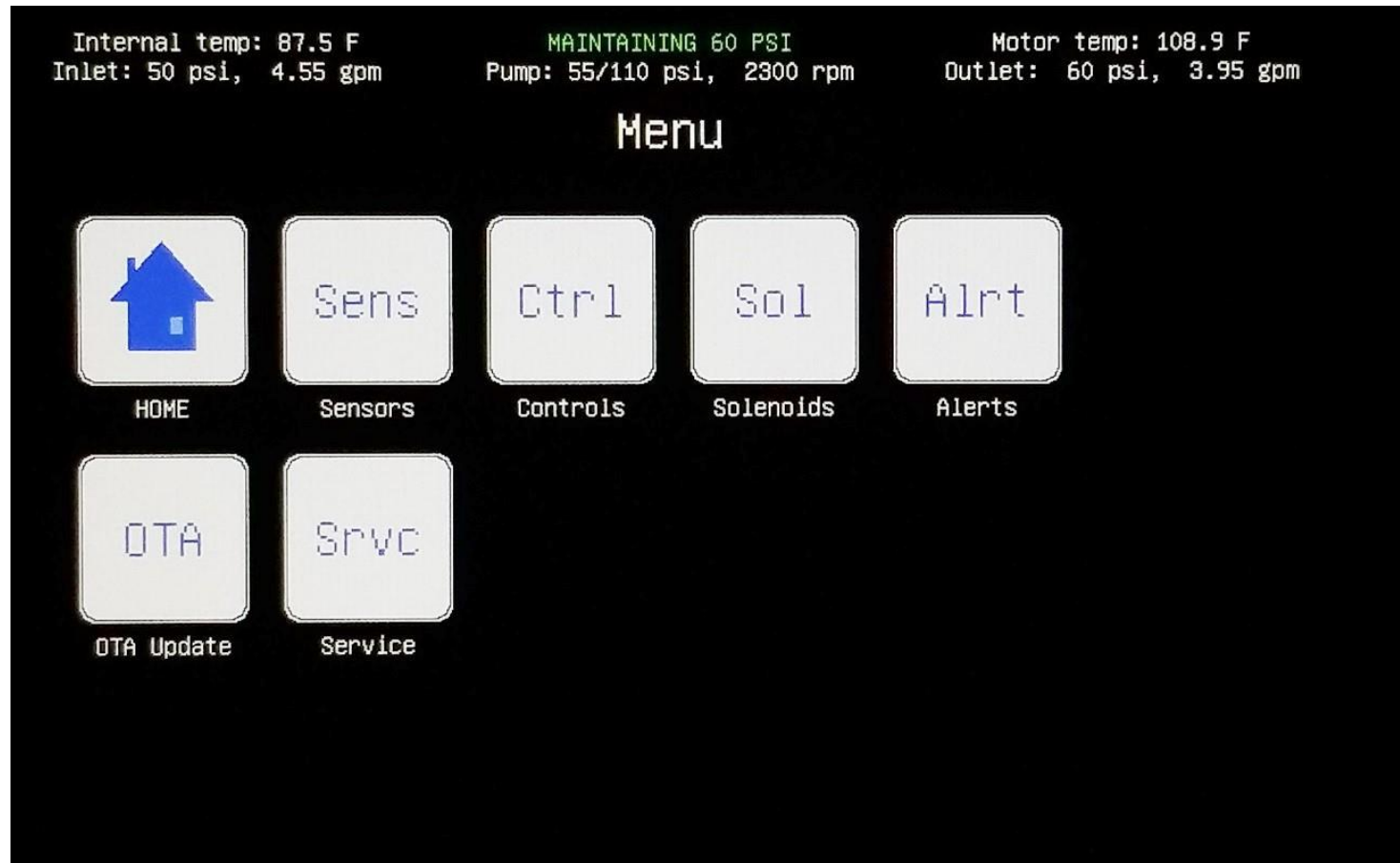

OTA is an acronym for over-the-air. Pressing the OTA button will produce a secondary confirmation window. The user may then select 'cancel' or 'upgrade'.

Operational States

The system has several operational states based on inputs, user selections, or system faults. The operational state is displayed at the center of the screen banner.

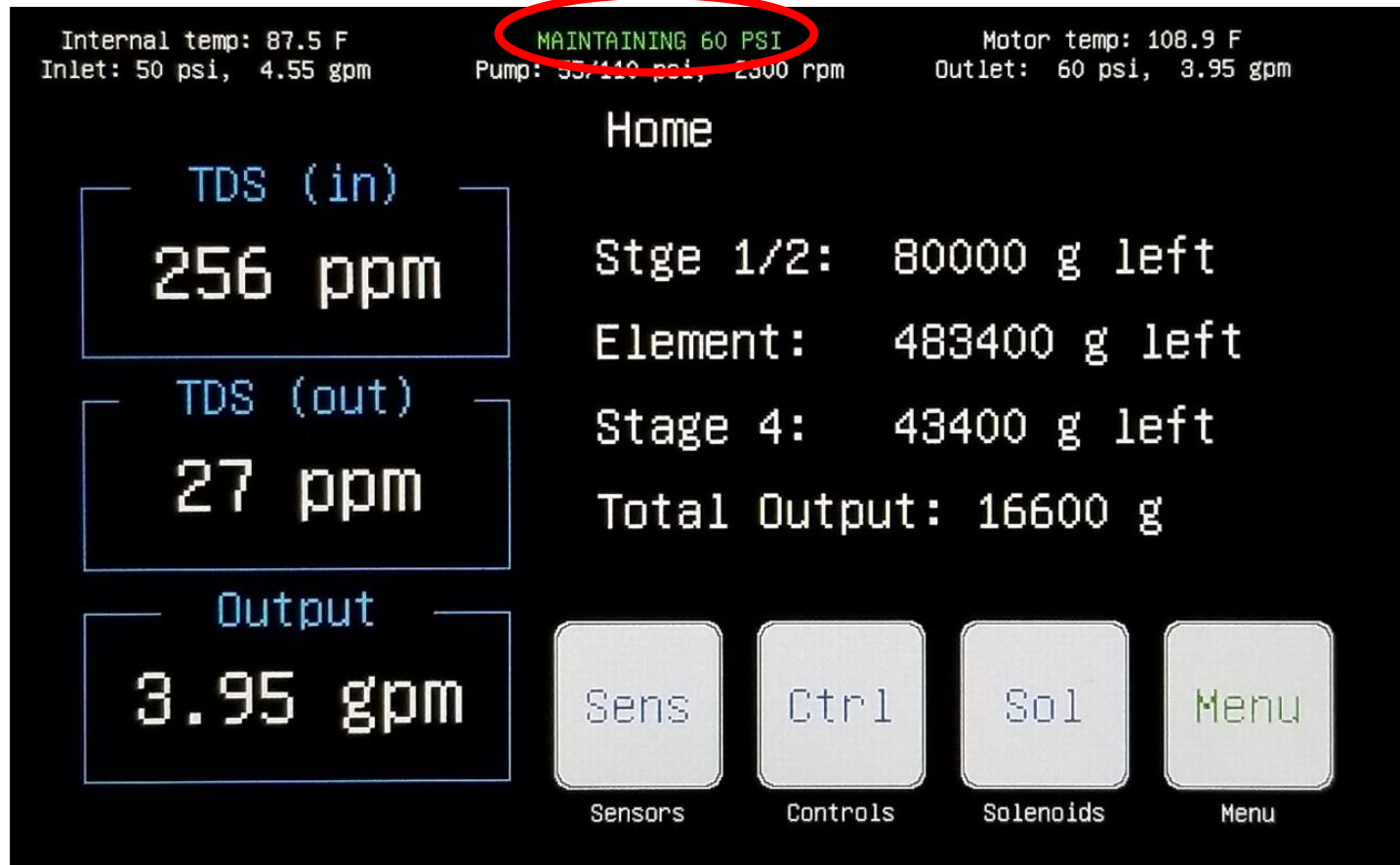

The top banner is universal across all screens and shows detailed operating data for the system.

Operational States (continued)

The following table lists all the operational states, along with a brief description of each.

Operational State	Description
24-Hour Flush	<p>A 24-hour flush occurs once the system has been in an idle state (no outlet flow) for twenty-four (24) consecutive hours.</p> <p>This is an automatic operation which does not require any additional action.</p>
Dormant Flush	<p>A dormant flush occurs once the system has been in an idle state (no outlet flow) for four (4) consecutive hours.</p> <p>This is an automatic operation which does not require any additional action.</p>
Drain Cycle	<p>The drain cycle opens all drain valves along with the flush valve and is used to drain the system during service and/or maintenance.</p> <p>This is a manual operation which is typically performed by a qualified technician.</p>
High Inlet Pressure Dump	<p>A high inlet pressure dump opens the drain valves for 3 seconds in order to relieve excessive internal or external pressure.</p> <p>This is an automatic operation which will occur repeatedly if the inlet pressure is above the system specifications.</p>
High Outlet Pressure Shutdown	<p>The high outlet pressure shutdown turns off the pump and opens the drain valves to release excessive internal pressure.</p> <p>This is an automatic operation which will remain in effect until the outlet pressure is below 70 psi.</p>
Idle Flush	<p>An idle flush occurs once the system enters an idle state (no outlet flow) following 30 minutes of cumulative operation since the last flush.</p> <p>This is an automatic operation which does not require any additional action.</p>

Operational States (continued)

Operation State	Description
Low Inlet Pressure Shutdown	<p>A low inlet pressure shutdown occurs when the inlet pressure is below 8 PSI for more than 5 continuous seconds or below 1 PSI for 1 second.</p> <p>This is an automatic operation which will remain in effect until the inlet pressure is above 30 PSI.</p>
Low Pump-Inlet Pressure Stg 1 - 4	<p>The low pump inlet pressure states occur when the pump inlet pressure drops below the required level for proper operation. There are four (4) stages which limit the pump motor speed to various levels depending on the input pressure. These states allow the unit to continue operating at lower input pressures.</p> <p>This is an automatic operation which will remain in effect until the pump inlet pressure is above 30 PSI.</p>
Maintaining 50 – 65 psi	<p>Maintaining pressure is the normal operating state of the system. In this state, the system is maintaining a specific outlet pressure. This pressure is based on the outlet flow rate. For lower outlet flow rates, the maintained pressure is higher.</p> <p>This is an automatic operation and indicates the system is running normally.</p>
Maintaining 2 – 6 gpm	<p>Maintaining flow is a custom operational setting for the system. In this state, the system is maintaining a specific output flow. This is typically used for multi-unit systems only.</p> <p>Once the setting is made, this is an automatic operation.</p>
Manual Mode	<p>Manual mode allows the system to be operated manually.</p> <p>This is a manual operation and should only be performed by a qualified technician.</p>
Motor Fault Shutdown	<p>A motor fault shutdown occurs when the system has experienced a critical fault related to the operation of the pump motor.</p> <p>This is an automatic operation which may require a system restart or evaluation by a qualified technician.</p>

Operational States (continued)

Operation State	Description
Running Flush	<p>A running flush occurs when the system has been continuously operating (continuous outlet flow) for more than 30 to 60 minutes, depending on the inlet water TDS.</p> <p>This is an automatic and relatively frequent operation which does not require any additional action.</p>
Start-up Cycle	<p>The start-up cycle is a manual operation used during initial start-up or after filter replacement.</p> <p>This is a manual operation and should only be performed by a qualified technician.</p>
Sani-Cycle	<p>The sani-cycle is a manual operation used during initial start-up and/or sanitization of the unit.</p> <p>This is a manual operation and should only be performed by a qualified technician.</p>

Warnings / Alerts - Alerts Screen

The alerts screen displays any active alerts or warnings.



From the home screen, select menu, then alerts.



The banner for the alerts screen is unique in that it displays Wi-Fi connectivity, device ID, and electronic hardware information.

Warnings / Alerts (continued)

The following table lists the potential warnings/alert that may appear and provides a description / potential solution. The top left corner of the universal banner on the display screen will read '**Check alerts**' when there is an active alert present. The message will remain on the banner and the alert will remain on the alerts screen until the condition no longer exists. *To view details of any active warning or alert(s), go to the Alerts ('Alrt') screen.*

Warning / Alert	Alert Message	Description / Solution
Low inlet pressure	Warning! Inlet pressure is too low!	<p>Check the inlet water supply (water being fed to the system) and make sure any necessary valves leading to the system are open. If a valve is closed, please open it to allow water to flow. Make sure the inlet water is not leaking.</p> <p>If you have a well, check for proper pressure in the well tank, making sure that the circuit breaker on the well pump is switched on. Ensure water is flowing through the well pump properly.</p> <p>Ensure you have a 40/60 well tank pressure switch. Set the minimum bound of the switch to 45 psi for best performance.</p>
High inlet pressure	Water inlet pressure is too high!	<p>Check the inlet water supply (water being fed to the system) and make sure the pressure is not over 60 psi. If the inlet pressure is above 60 psi, a pressure regulating valve (PRV) will need to be installed.</p> <p>If you have a well, check for proper pressure in the well tank, make sure that the well pump pressure switch is properly suited for this application (i.e. 40-60 psi).</p>

Warnings / Alerts (continued)

Warning / Alert	Alert Message	Description / Solution
High pump pressure	<p>In High Pump Pressure Shutdown!</p> <p>Contact Customer Service.</p>	<p>The pressure is too high, and the pump has now shut off. Check to make sure that your Stage 3 element is not blocked. Clear any blockages, including inappropriately closed valves. If the issue remains, contact Customer Service.</p>
Pump motor controller fault	<p>Pump Motor Controller Fault – In Shutdown!!</p> <p>Contact Service Immediately</p>	<p>Restart the system to determine if it will clear the fault (see page 26). If not, contact Customer Service.</p>
Pump speed fault alert	<p>Pump Speed Error!!</p> <p>Pump turned off</p> <p>Contact Service Immediately</p>	<p>Restart the system to determine if it will clear the fault (see page 26). If not, contact Customer Service.</p>
Solenoid driver fault	<p>Solenoid driver fault!</p> <p>Contact customer service.</p>	<p>Restart the system to determine if it will clear the fault (see page 26). If not, contact Customer Service.</p>

Warnings / Alerts (continued)

Warning / Alert	Alert Message	Description / Solution
Low outlet pressure (shutdown)	Low outlet pressure! Check sensor!	<p>A low outlet pressure shutdown will occur when the outlet pressure reads at below 1 psi for more than 5-10 seconds (depending on outlet flow). The unit will automatically shut down and remain in this state until outlet pressure is restored for a minimum of 30 seconds.</p> <p>This may be caused by a failure in the outlet pressure sensor or an issue downstream from the unit. If the issue persists, contact Customer Service.</p>
High outlet pressure (shutdown)	<p>Outlet pressure too high! Check IMMEDIATELY!</p> <p>Pump will be re-enabled when pressure <70 PSI</p>	<p>The system is designed to prevent over-pressurization by prevent pump operation when the outlet pressure is above 80 psi.</p>
High Inlet TDS	ALERT!! Elevated Inlet TDS!	<p>The system is not designed to handle inlet water TDS above 3000 (1500 TDS for Model 2R).</p> <p>Confirm that the inlet water TDS is below 3000. If so, replace the inlet TDS sensor and confirm the inlet water TDS settings under the setup screen.</p>
High Outlet TDS	ALERT!! Elevated Outlet TDS!	<p>Outlet TDS is above 500. If the outlet TDS is above this threshold the system will continue to operate but in an active alert state.</p> <p>If the alert state persists, contact Customer Service.</p>

Warnings / Alerts (continued)

Warning / Alert	Alert Message	Description / Solution
Stage 1&2 – Check Filters	Stage 1&2 – Check filters for potential blockage.	This alert indicates a potential blockage or fouling of the filter cartridges in Stage 1&2. The system should continue to run but the performance may be reduced. If the warning persists, please contact Customer Service.
Stage 1&2 - 10% life	Warning! Stage 1&2 filters have <10% life remaining. Replace soon.	This message serves as a reminder to schedule your regular system maintenance. Please contact Customer Service.
Stage 1&2 - 10% VOC life	Stage 1&2 filters have <10% VOC filtration life remaining.	Carbon filters have <10% VOC filtration capacity remaining.
Stage 1&2 - 0% life	ALERT!! Stage 1&2 filters have expired. Replace IMMEDIATELY!!	Using an expired filter affects the overall cleanliness of the output water and can damage the Elements Please replace the Stage 1 & 2 filters right away to keep your water as clean as possible.
Stage 1&2 - 0% VOC life	VOC filtration has expired.	The VOC capacity for the carbon filters has expired.
Element - 10% life	Warning! Element has <10% life. Service soon.	This message serves as a reminder to schedule your regular system maintenance. Please contact Customer Service.
Element - 0% life	ALERT!! Element has expired. Service IMMEDIATELY!	Using an expired element affects the overall cleanliness of the output water. Please service the RO element right away to keep your water as clean as possible.

Warnings / Alerts (continued)

Warning / Alert	Alert Message	Description / Solution
Stage 4 - 10% life	Stage 4 filter has <10% life remaining. Replace soon.	This message serves as a reminder to schedule your regular system maintenance. Please contact Customer Service.
Stage 4 - 0% life	ALERT!! Stage 4 filter has expired. Replace IMMEDIATELY!	Using an expired filter affects the overall acidity of the output water. Please replace the Stage 4 filter right away to keep your water as balanced as possible.
Motor Temperature Alert	ALERT!! Motor over-temp Shutdown! Contact Customer Service	The pump motor has over-heated, check to make sure the motor fans are operating properly and that nothing is blocking the vents in the side panels. If the alert state persists, contact Customer Service.
Electronics Temperature Alert	Electronics over-temp Shutdown! Contact Customer Service	The system has detected an elevated temperature in the electronics box (e-box). The system will automatically resume operation when temperature has normalized. If the alert state persists, contact Customer Service.
TDS Sensor Alert	Check TDS sensors.	The inlet TDS sensor appears to not be functioning properly. If the alert state persists, contact Customer Service.

Troubleshooting

1. Display screen will not turn on

- ✓ Confirm the power supply is properly connected at the rear of the machine and the base of the e-box.
- ✓ If power supply is properly connected, perform a power cycle by disconnecting the unit from the power supply, wait 30 seconds, and reconnect power. If a power cycle does not fix the issue, replace the e-box (refer to the Service & Maintenance manual P/N 8920).

2. Pump will not run

- ✓ Confirm the pump wire harness is properly connected to the side of the e-box.
- ✓ Confirm the system shows a minimum of 30 psi inlet pressure.
- ✓ If an audible beeping noise is heard from the e-box, perform a system restart (see page 26) . If a system restart does not fix the issue, replace the e-box (refer to the Service & Maintenance manual P/N 8920).

3. Low inlet pressure

- ✓ Confirm inlet water supply has been restored.
- ✓ If pressure is present in the system and the inlet pressure sensor is reading 0 psi, replace the sensor.

4. Wi-Fi will not connect

- ✓ Ensure a strong Wi-Fi signal is present from the router. A range extender may be required in certain areas, such as basements, where the signal may not be reliable.

5. TDS values are not changing

- ✓ TDS sensors require 1-minute of continuous operation before providing a dynamic reading.
- ✓ If a TDS value is well outside the expected range (based on pre-installation water testing), replace the sensor.